

FB6-E0176
2013. 5.14

# I N S T R U C T I O N M A N U A L

*T E X E L*

*C H E M I C A L F A N S*

**MODEL: FTF SERIES**



**TEXEL-SEIKOW U.S.A., Inc.**

4404 W12th St

Houston, TX 77055

TEL (1) 713-683-1505

FAX (1) 713-417-3932

## Preface

Thank you for purchasing a Texel Corrosion Resistant Fan in the FTF Series.

FTF series fans are high-performance fans mainly made of FRP (Fiberglass Reinforced Plastic) which offers superior corrosion resistance to all types of corrosive gas.

Handling and operation of these fans are pretty simple, however if operated not as directed, it may result in a malfunction.

Please read this instruction manual carefully for correct handling and operation.

## Checklist upon arrival

When the product arrives, please check the following:

- 1) Check to ensure that static pressure, gas volume, and motor record on the nameplate are correct.
- 2) Check to ensure that no components have been damaged in transit.
- 3) Check to ensure that all accessories are supplied.

## Names of Parts

Fig.1 Structural Drawing (FTF303,403)

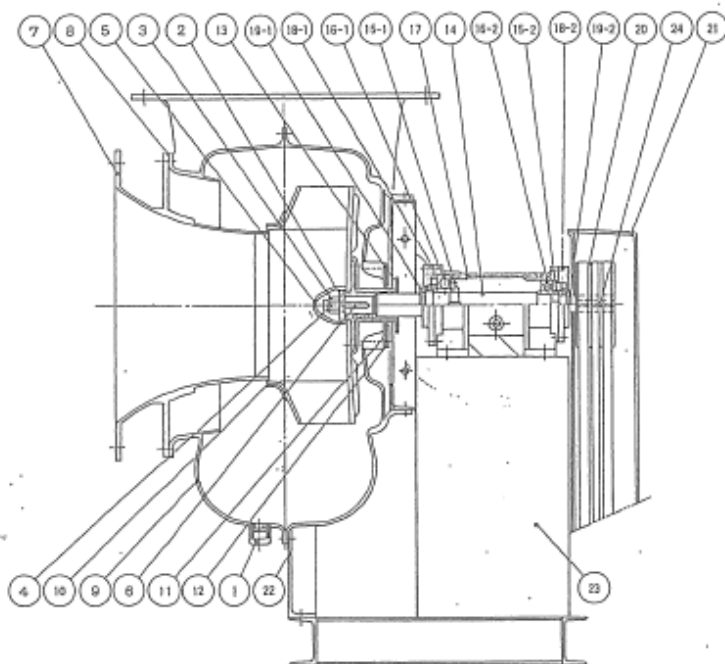

No.	Name of Part	Material	Qt.
1	Drain	FRP	1
2	Impeller Washer	SS400	1
3	Impeller Nut	S25C	1
4	Split Pin	SWRM6	1
5	Nut Cover	FRP	1
6	Impeller Key	S45C	1
7	Suction Cone	FRP	1
8	Casing Gasket	EPT	1
9	Casing	FRP	1
10	Impeller	FRP	1
11	Seal Plate	P.E	1
12	Seal Tight Plate	FRP	1
13	Gas Separator	HTPVC	1
14	Shaft	S45C	1
15-1	Bearing Nut,Washer	SS	1set
15-2	Bearing Nut,Washer	SS	1set
16-1	Bearing(F)	SUJ2	1
16-2	Bearing(R)	SUJ2	1
17	Bearing Housing	FCD450	1
18-1	Bearing Cover(F)	FC200	1
18-2	Bearing Cover(R)	FC200	1
19-1	V-Ring(F)	NBR	1
19-2	V-Ring(R)	NBR	1
20	V-Belt,Pulley	---	1set
21	Belt Guard	FRP	1
22	Casing Support	FRP	1
23	Bracket	SS400	1
24	Pulley Key	S45C	1

## TRANSPORTATION



### WARNING

#### Do not lift fan by the casing

To lift the fan, use the lifting hook bolts. The fan may break if lifted at parts other than the lifting hook bolts.

Note: Do not use the motor lifting bolt to lift the fan.

If the belt and bearing are covered by a single safety cover, dismantle it to gain access to the hook bolt.



### WARNING

#### DO NOT USE FAN AS A FOOTREST

The casing and safety covers are fragile and could break leading to accident if used as a footrest.



## STORAGE

#### STORE FAN INDOORS

Exposure of fan bearings to water or dampness for long periods may damage the bearing and the V-belts. For long-term storage, remove the belt and store it in a dry place where it is not exposed to the sun

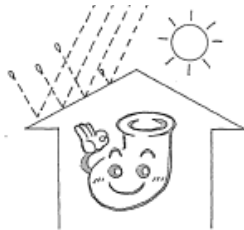

#### COVER FAN WITH SHEET DURING CONSTRUCTION

Bearings may be damaged if contaminated by water or dirt. Cover the entire fan with a waterproof sheet to prevent water and dirt from getting in.

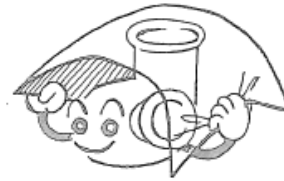

## INSTALLATION

#### MINIMUM FREE SPACE AROUND FAN: 60 cm

Create ample space around the fan to ease bearing change and maintenance and to help dissipate heat

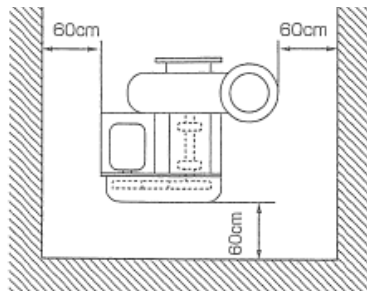

#### MOUNT FAN ON A SOLID FOUNDATION

A weak foundation or uneven surface will lead to abnormalities in operation and functioning.

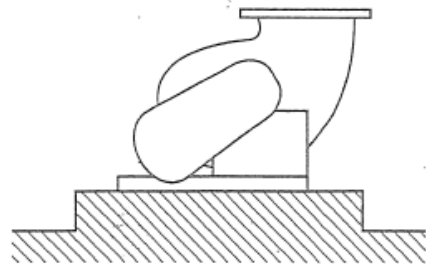

## PIPING



### WARNING

#### USE SUPPORTS, VIBRATION-PROOF JOINTS AND SHORT PIPES

The casing may deform and collide with the impeller if excess force is exerted on the fan due to piping load and vibration.

Supports and vibration-proof joints should always be used.

For easy maintenance at the suction side, attach an extension pipe at a distance of 1.5 times of the Distance "D". (See the picture below)

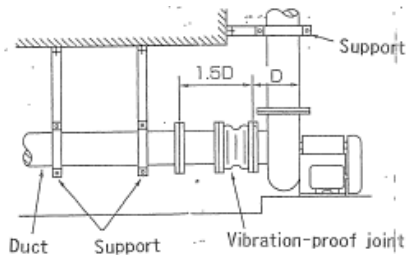

### WARNING

#### SAFETY MEASURES FOR THE DISCHARGE OPENING

If the impeller breaks and the discharge opening is located horizontally, fragments could pierce through the duct and cause injury to personnel or damage to other equipment.

Install a protector if the discharge opening faces a passageway.

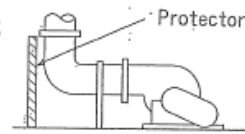

### WARNING

#### MEASURES TO PREVENT THE SUCTION & DISCHARGE OF DEBRIS

Suction of debris when the fan is running could lead to damage of the impeller.

Adopt measures to prevent debris from collision with the impeller.

#### ATTACH SUPPORTS TO VENTILATOR

Winds may exert strong forces on a ventilator that could damage the fan.

Always be sure to attach supports

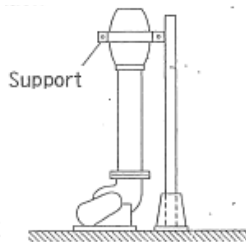

#### ENSURE SMOOTHNESS OF DUCTS

In the drawing below, the ducts with the profile denoted by dotted lines cause an increase in vibration and performance loss

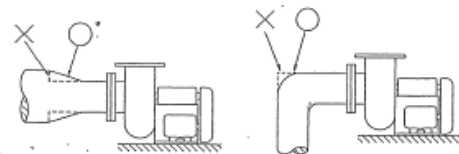

### CAUTION

#### USE GUIDE VANES ON RIGHT-ANGLE ELBOWS

A 90° elbow causes excessive vibration and a decline in fan performance when attached to the suction side.

For a case like the one shown below use a guide vane.

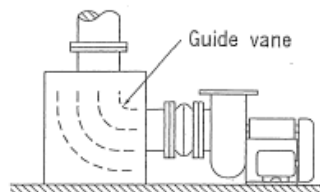

### CAUTION

#### DRAIN THE FAN CASING

If the handled gas contains mist, vapor or dust, install a drain

and make sure the casing is drained regularly.



## Electrical Wiring

- 1) Wiring should comply with the electrical standards and the specifications of your local government or electric power company requirements.
- 2) Connect the wires temporarily to determine the correct rotational direction of the fan. The rotational direction should comply with the direction shown by the arrow on the motor.

## Precautions on Initial Operation

- 1) Check peripheral machines and inside the fan casing to make sure that no foreign objects or tools have been left inside by oversight during installation.
- 2) During the initial operation, start with the damper completely closed. When the motor has attained its rated speed, slowly open the damper, and adjust to the specified gas volume.
- 3) If the fan is run at full capacity immediately, the motor may overload which could lead to a breakdown of the electrical system.
- 4) A star-delta starter is recommended for a smooth start of the operation for fans over 7HP.

### RUNNING PRECAUTIONS



**DANGER**

**DO NOT EXCEED THE MAXIMUM TEMPERATURE**  
(Max temperature stated on nameplate)

The gas temperature must not exceed the maximum value as it may result in impeller damage.

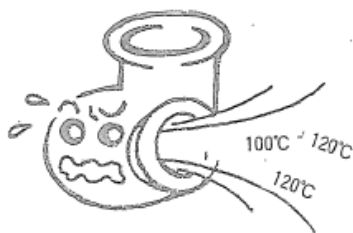

**CAUTION**

**DO NOT EXCEED THE RATED CURRENT**

Depending on the state of the gas, a surge in shaft power may cause the motor to burn out. Use an ammeter to check the current.

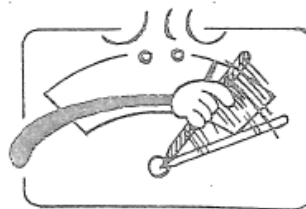



**DANGER**

**DO NOT TOUCH ROTATING PARTS**

Be careful that your hands or clothes do not get entangled with rotating parts.

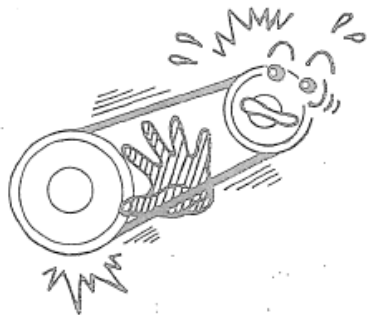

**DANGER**

**DO NOT DISMANTLE THE SAFETY GUARDS**

It is very dangerous to operate the fan without the belt and shaft guards attached.

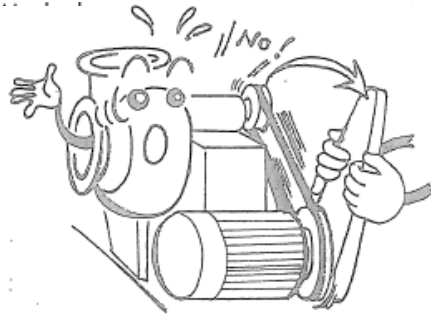

**WARNING**

**CLOSED OPERATION FOR A LONG PERIOD IS PROHIBITED**

Running the fan continuously with the damper completely closed will cause heat buildup and impeller failure.



**WARNING**

**DO NOT RUB DUST ON THE IMPELLER**

Accumulation of dust on the impeller may cause vibration and impeller failure. Clean the impeller periodically.



**WARNING**

**DO NOT MOUNT ON THE FAN**

Mounting or leaning against the shaft and belt guards may break them leading to a mishap.



**WARNING**

**SWITCH OFF FAN AND REMOVE BELT BEFORE INSPECTING THE CASING INTERIOR**

Severe bodily harm may be inflicted if the interior of the casing is inspected while the fan is running. Switch off the fan, place an "Inspection-in-Process" tag, and then remove the belt.

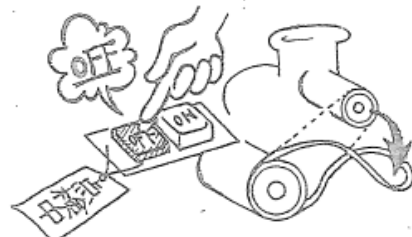

## Maintenance & Inspection

General maintenance and inspection is recommended once a year even if no abnormalities are observed under operating conditions.

### 1) Bearing Temperature

a. Bearing temperature should not differentiate more than 104 °F from the ambient temperature.

b. For a fan of 3600 rpm speed, the temperature should not differentiate more than 122° F from the ambient temperature.

The maximum temperature of the bearing housing surface is 176° F.

### 2) Bearing Vibration

Exceptionally large vibrations have a negative influence on the bearings and in worst cases could lead to breakage of the impeller.

Measure the bearing housing vibration with a vibration meter. If the registered value is higher than the standard value shown in Fig. 2, inspect the following points:

#### Causes of and Countermeasures for Vibration Readings Higher than Standard Values

Cause	Countermeasure
Looseness of anchor bolts	Tighten anchor bolts
Looseness of bearing	Replace bearing
Looseness of bearing set bolts	Tighten bearing set bolts
Imbalance of impeller due to adhesion of scales	Wash away scales thoroughly
Misalignment of pulley	Adjust pulley
Misalignment of Belt	Adjust belt tension and position

Fig.2 Permissible Values of Vibrations on Bearing Housing  
JIS B 8330 (Given for Reference)

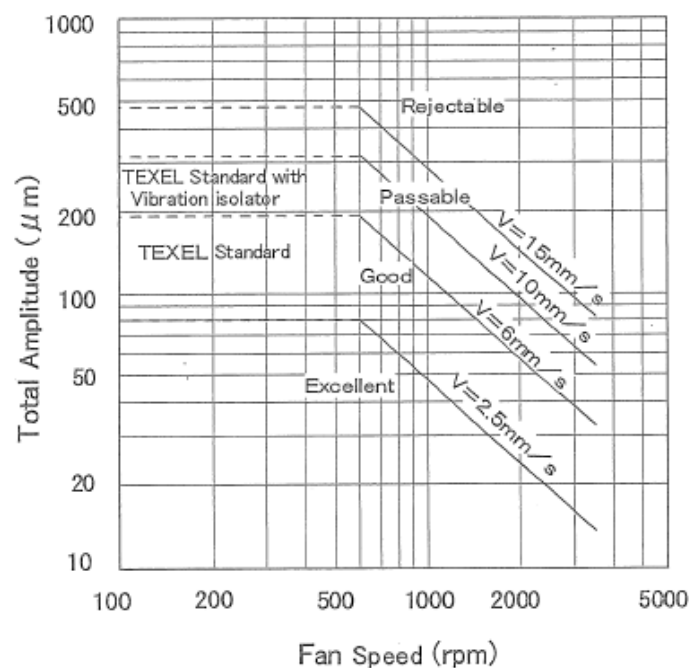

Reference: The relation between the total amplitude  $a$  ( $\mu m$ ) and velocity of vibration  $v$  (mm/s) is as given below.

$$V = a \cdot \omega / 2 \times 10^3 = a \cdot \omega \cdot n / 6 \times 10^4 \quad \omega: \text{angular velocity} = 2\pi n / 60 \quad (\text{rad/s})$$

$n$ : number of revolutions (rpm)

### 3) Inspection and Adjustment of Pulley and Belt

#### a. Misalignment of Pulley

Misalignment of the pulley exceeding the standard value can cause slipping, premature friction, and breakage of the pulley. The pulley should be adjusted whenever the belt tension is adjusted. The standard allowance of misalignment value is within an angle of  $7'$ .

In the case of "d", adjust within  $d < 0.0012A$ .

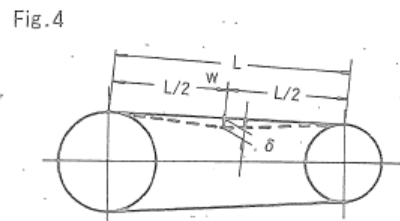
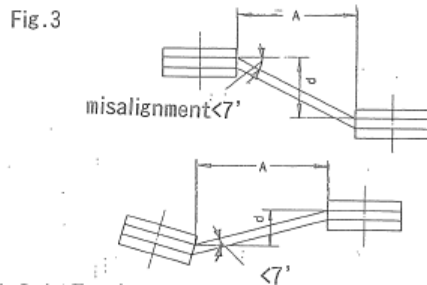

#### b. Belt Tension

If the belt is too tight, the bearings and shaft will be under excessive load, which may result in breakdown, while insufficient tension may cause slipping of the belt, which may shorten its life span due to generation of heat. It should also be noted that the belt tends to stretch, particularly during the first week of fan operation. Please conduct a check regularly to ensure the belt tension is sufficient, and adjust if necessary.

In order for the belt to transmit power efficiently (without slipping), it needs to be adjusted to the appropriate degree of tension.

- Measure the belt Span L: Length of the part of the belt that is not in contact with the pulley groove.
- Use a spring scale on the center of span L to apply weight  $w$  at a right-angle to the belt, and convert the deflection "d" gained at this point using the equation below " $d$ " =  $0.016 \times L$  (mm)
- Now use the Motor slide base to adjust the tension of the belt so that the weight  $W$  falls within the range shown in Fig. 5.

Fig. 5. Belt tension (Given for Reference)

V Belt Type	Pulley Diameter	W kgf	V Belt Type	Pulley Diameter	W kgf
A	81 — 106	1.4 — 2.3	3V	67 — 90	2.2 — 2.5
	107 —	2.4 — 2.7		91 —	2.3 — 3.4
B	106 — 160	2.9 — 3.9	5V	180 — 310	6 — 9
	161 —	3.7 — 4.2		311 —	6.8 — 10.5



#### 4) Belt Life

The life span of the belt is approximately 1 year when used 24 hours a day. Please use this as a criterion for replacement.

#### 5) Lubrication Oil

- a. Check adequacy of oil. Inspection of the lubricating oil should be performed daily.
- b. Replace the entire lubricating oil at least once a year.
- c. Turbine oil #32 or its equivalent is recommended. Our standard is Shell Oil type C32 unless otherwise specified by the clients.
- d. Check the oil gage for dirt. If dirty, change it.
- a. Check oil level.

Model	FTF153	FTF203	FTF253	FTF303	FTF403
Quantity	2.36oz	4.39oz	4.39oz	6.76oz	11.83oz
Model	FTF503	FTF603	FTF703	FTF803	FTF903
Quantity	28.74oz	28.74oz	83.18oz	83.18oz	94.68oz

## Main Points for bearing Replacement

- a. Stop the fan and wait until the bearing temperature drops to normal before performing the bearing replacement.
- b. Drain the bearing housing oil.
- c. Mark the mounted position of the bearing housing (1).
- d. Unfasten the bearing housing mounting bolts.
- e. Detach the front and rear bearing cover (4-1) V-rings (6-1), (6-2).
- f. Detach the bearing cover (4-1) on the impeller side.

Fig.6 Structural Drawing of Shaft and Bearing

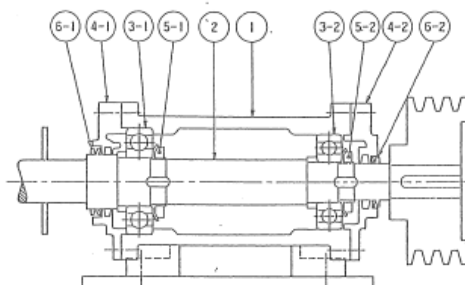

- g. Strike the shaft on the pulley side lightly with a wooden hammer and detach the entire bearing housing by pulling it backwards.
- h. Loosen the front and rear bearing nuts (5-1), (5-2).
- i. Extract the bearing with a bearing extracting device.

## **2) Insertion of Bearing**

The procedure for insertion of the new bearing is the opposite of that for extraction. Attention should be paid to the following points.

- a. Do not forget to replace parts which come before the bearing such as guide ring, nut, washer, and spacer.
- b. Heating the bearing will make it easier to insert. (Use a bearing heater or heated oil.) The heat should not exceed 248° F.
- c. When handling the bearing, make sure that it is not contaminated by dust.

## **Disassembly of Impeller**

- 1) Remove the nut cover, which is bonded lightly to the main plate, by using a chisel or similar tool.
- 2) Removal of the nut cover will reveal a castle nut and split pin, which should also be detached.
- 3) Holes are provided on the boss part in the impeller; insert bolts in these holes, set the pulley-puller in place, and proceed to remove the impeller from the shaft.